

CINCINNATI[®]

QUICKSET PRESS BRAKE DIES

Increase Your Profits with Precision Tooling

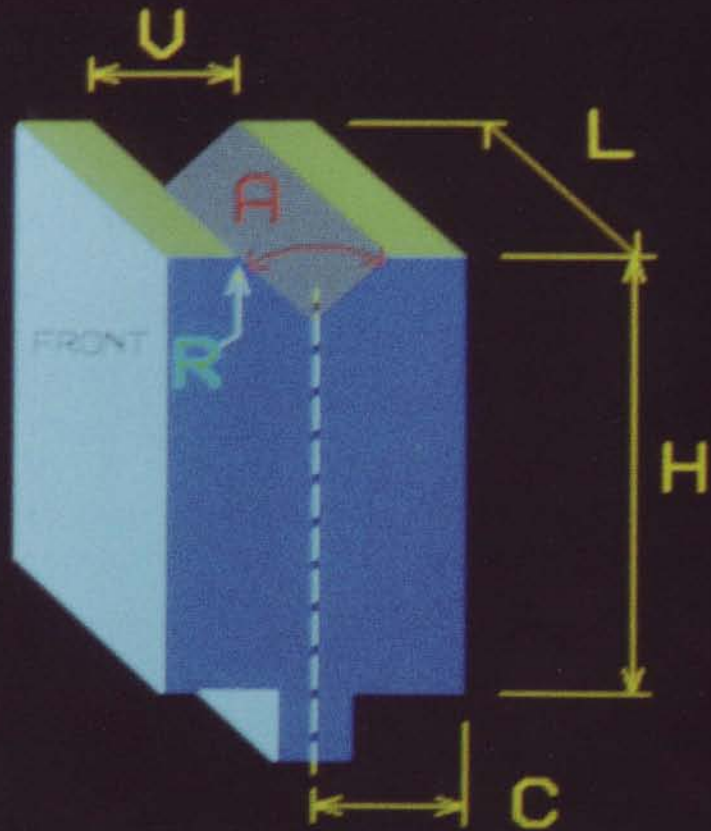
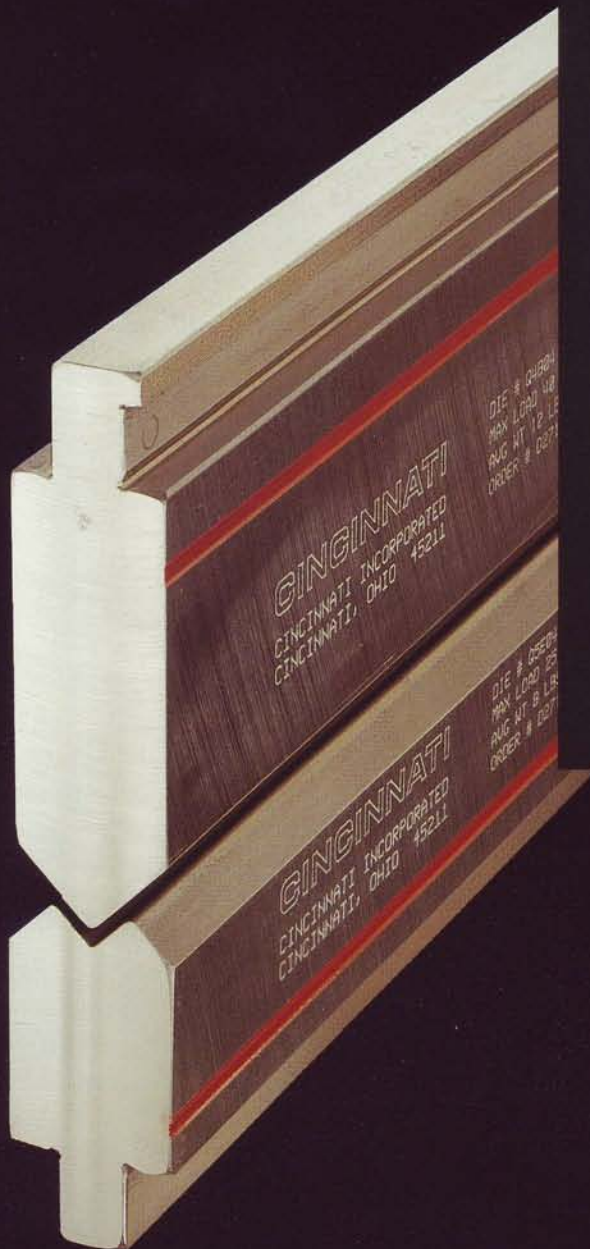

MORE PARTS PER DIE Our precision dies are made of 80 to 90 high carbon brake die steel, heat-treated throughout, 245 to 290 Brinell. Each die is tough and wear resistant. They can be remachined without the necessity to anneal and reharden.

WIDEST SELECTION ANYWHERE We offer over 43 types; air bend, acute angle, bottoming, and gooseneck dies, in lengths from 25" to 194".

IMPROVED PART QUALITY Our dies are machined to a smooth finish and precision tolerances.

FIT MOST PRESS BRAKES All standard tongues are $\frac{5}{8}$ " height x $\frac{1}{2}$ " width.

CINCINNATI can supply any normal cross section, nose radius, included angle, or tooling combination as required by the application. Contact Cincinnati for your specific requirements.

CINCINNATI

QUICKSET PRESS BRAKE DIES

Quickset tooling provides users with major benefits over conventional tooling:

QUICK SET UP:

The exceptionally tight tolerances held on CINCINNATI Quickset tooling allows die changeover without realigning the filler block. Quickset tooling is ideal for press brake applications using the Power Clamp option for upper and lower dies.

ACCURACY:

The 75° included angle shown, enables "true" air bending to be performed which takes full advantage of the technology built into CINCINNATI press brakes.

The 75° dies will accommodate up to 15° of springback when forming 90° bends, which can occur on a variety of today's materials. Alternately, 30° dies will provide the capability to form 90° bends or smaller included angles.

VERSATILITY:

Dies can be segmented with confidence since all sections will nest together with minimum misalignment. Master templates are maintained at CINCINNATI for all dies shown to ensure that any future requirement will be machined to a similar cross sectional tolerance.

Quickset die shipments include a data sheet of cross sectional dimensions for ease of input to the AUTOFORM® control.

All dies shown represent the most popular "Quickset Tooling" requested. CINCINNATI can supply any normal cross section, nose radius, included angle, or tooling combination as required by the application. Contact Cincinnati for your specific requirements.

AIR BEND DIES

All included angles **75°**

Included angle for both upper and lower dies allows for overbending material to compensate for springback. Angles from very shallow to 90 degrees are formed by adjusting the press brake ram.

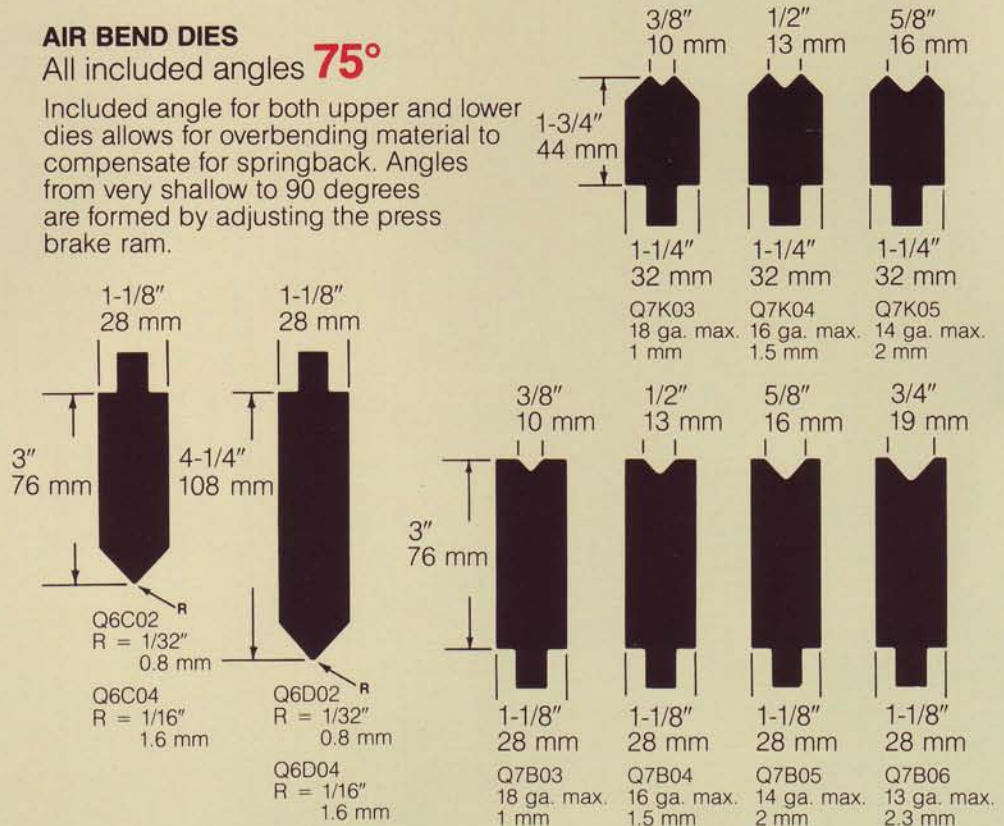

ACUTE ANGLE DIES

All included angles **30°**

Acute angle dies are used for air bends from very shallow angles up to 30 degree angles. The angle formed depends on the depth to which the upper die enters the lower die. Acute angle dies are commonly used to preform hems.

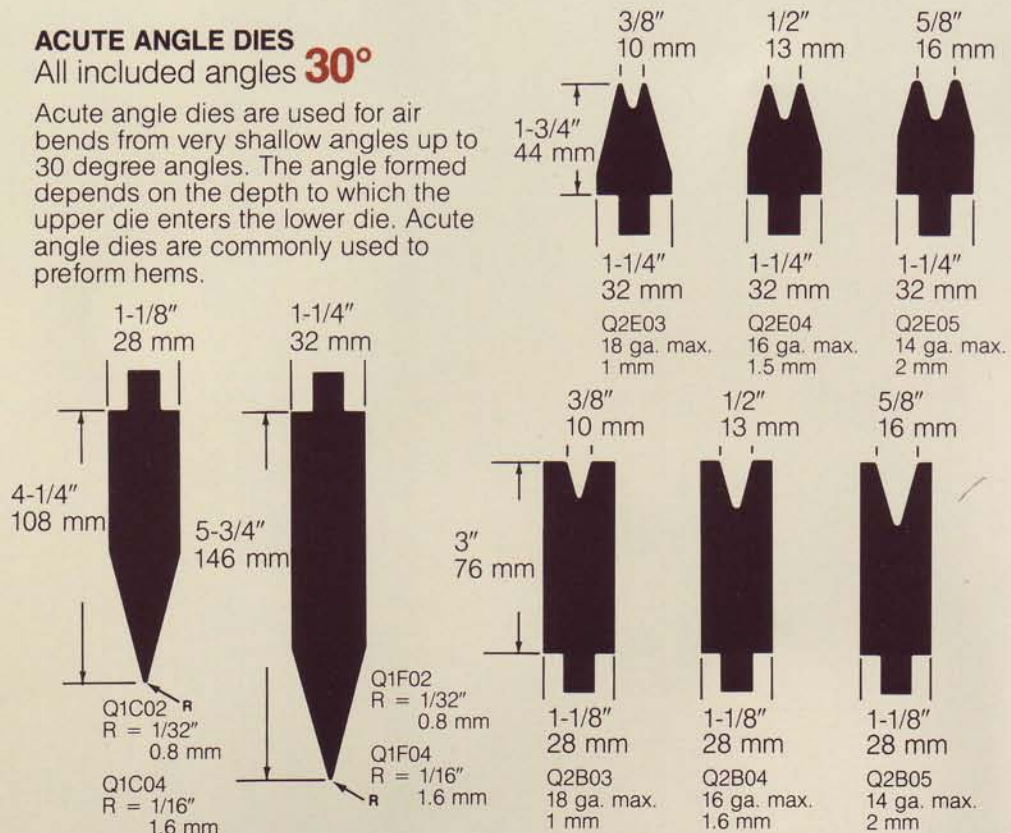

DIE LENGTH CODES

B	D	F	H	K	M	P	R
25"	49"	73"	97"	122"	146"	170"	194"
2'-1"	4'-1"	6'-1"	8'-1"	10'-2"	12'-2"	14'-2"	16'-2"
635mm	1240mm	1850mm	2460mm	3100mm	3700mm	4300mm	4900mm

All tongues are 5/8" (16mm) high x 1/2" (13mm) wide. "R" equals upper die nose radius and should not be confused with inside radius of angle formed by die. Overall die dimensions are nominal. Capacity shown is for mild steel. Refer to Cincinnati Press Brake Capacities bulletin for additional information.

BOTTOMING DIES

All included angles **90°**

Bottoming dies are used for making very accurate bends with relatively sharp inside radii in light gauge material, such as 12 gauge and thinner. Included angle is 90 degrees for both upper and lower dies.

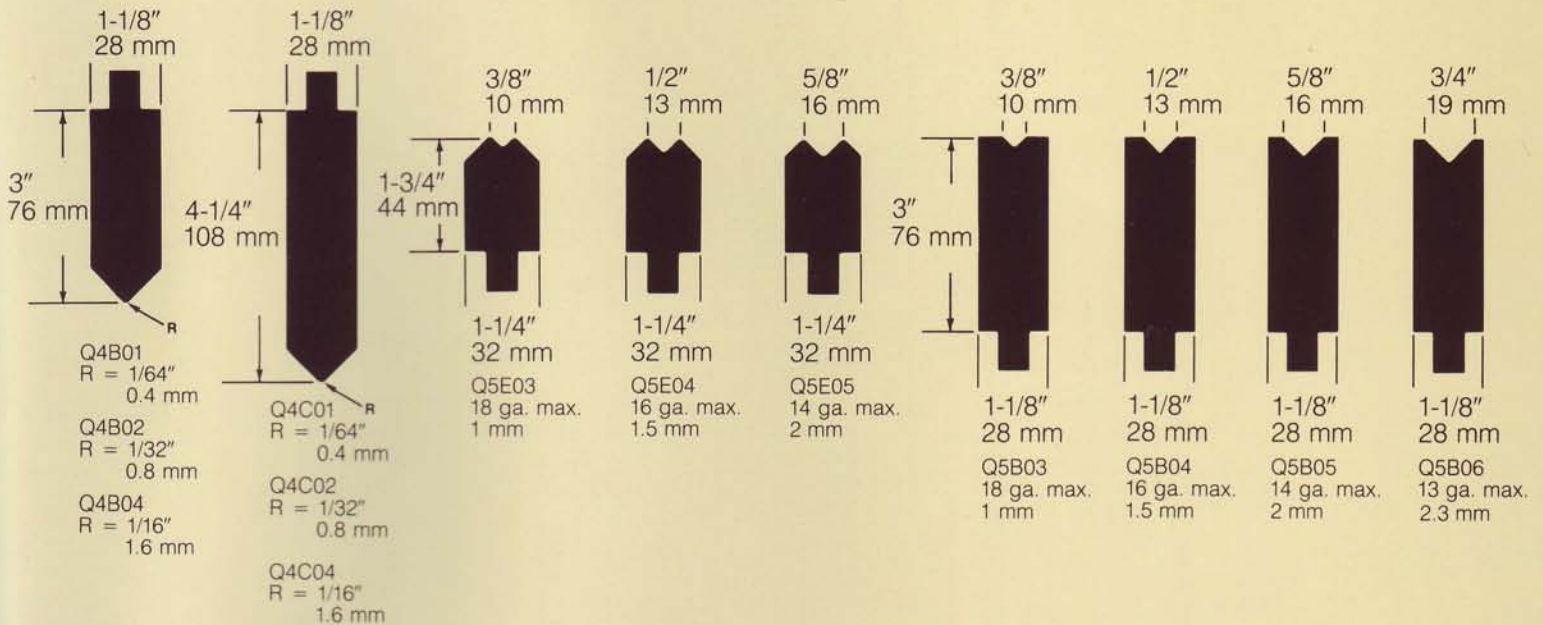

GOOSENECK DIES

Included angles of **75°**, **30°** and **90°**

Gooseneck dies are used for making channels or special shapes with which a straight sided die would interfere. A deeper "throat" beyond the die centerline increases width of return flange but reduces die capacity.

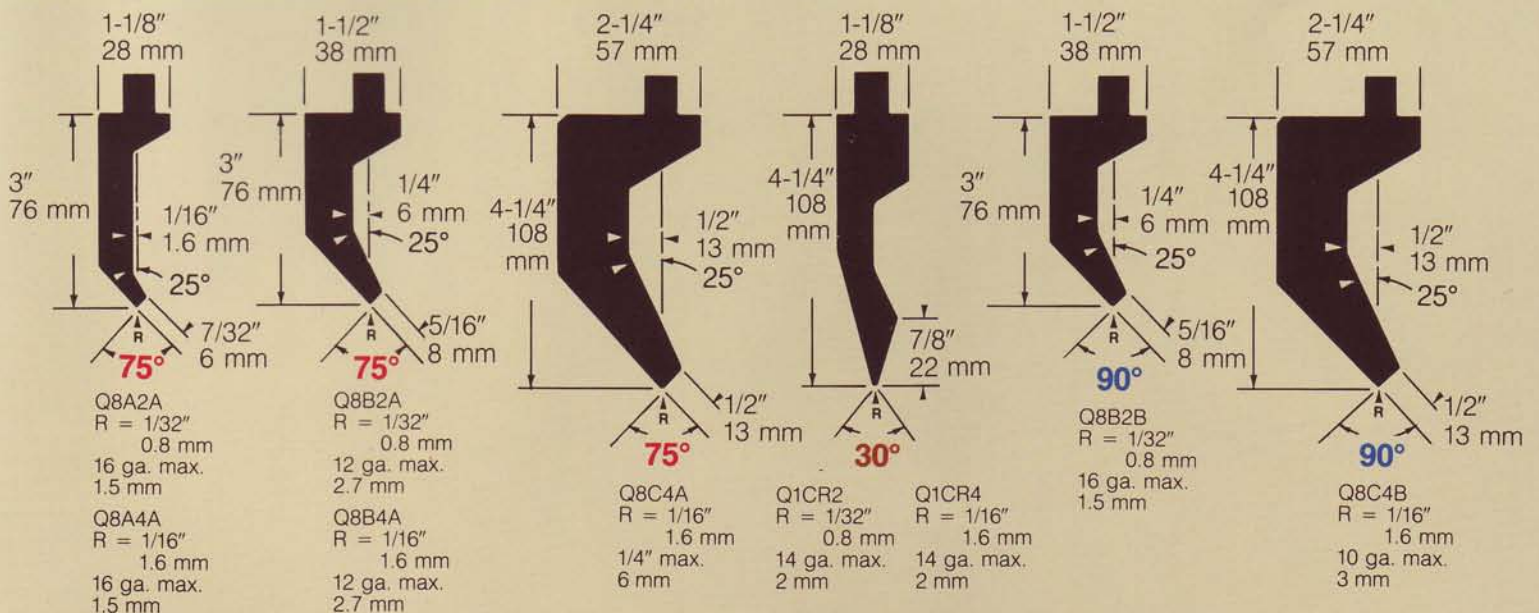

CINCINNATI® AUTOFORM CNC FORMING CENTER QUICKSET PRESS BRAKE DIES Your Performance Advantage



TOOLING MENU	
TOOL NAME	L2
TOOL TYPE	VEE
VEE OPENING (V)	0.375
RADIUS (R)	0.0460
ANGLE (A)	90.00
HEIGHT (H)	3.065
LENGTH (L)	96.00
CLEARANCE (C)	0.525
MAXIMUM LOADING	60.0 tons/ft

CINCINNATI Autoform CNC Forming Center utilizes a proven press brake design and incorporates the latest technology in hydraulics, controls and software for state-of-the-art forming. This highly productive machine in combination with CINCINNATI press brake dies offers unchallenged bend accuracy with greater versatility and faster changeover than any other conventional press brake. CINCINNATI single source responsibility is a demonstration of our commitment to ensure—Your Performance Advantage.

CINCINNATI Quickset press brake dies offer uncompromised quality for performance, versatility and durability. CINCINNATI has designed and manufactured press brake tooling for over 70 years and offers this practical experience and technical knowledge to help solve your fabrication requirements.

Quickset press brake tools are supplied with a tooling menu sheet which can be used to enter new data into the Autoform's tooling

library or update the existing file after tool modifications. Use of the tooling library eliminates the need to calibrate the ram and most gage combinations to the selected tooling, thus reducing overall setup time. The graphic color display of the upper or lower tool mentally orients the operator to verify setup information and that proper dies are being used. Replacement Quickset dies can be duplicated using the tooling menu information which CINCINNATI maintains on file.

Quickset press brake dies will help to increase your profits by reducing operator setup time, aid efficient processing of material and improve the quality of formed parts.

Additionally, CINCINNATI offers stock, standard and special dies for your application needs.

Contact CINCINNATI today with your forming requirements.

KEEP SAFETY IN MIND

Each press brake operation must be evaluated to determine the appropriate point of operation safeguarding to use. Consult the American National Standards Institute (ANS B11.3 safety standard), National Safety Council and similar sources for safeguarding help. The press brake operator should consult his superior if his operation is not properly safeguarded. Safety manuals, safety guidelines for operator and service personnel and a book with press brake safeguarding suggestions are available from CINCINNATI. If you do not have them call or write for them now.

Contact our nearest area office or the factory direct: (513) 367-7528 FAX: (513) 367-7552

Website: www.e-ei.com E-mail: info@e-ei.com

CINCINNATI

CINCINNATI INCORPORATED

Box 11111, Cincinnati, Ohio 45211